

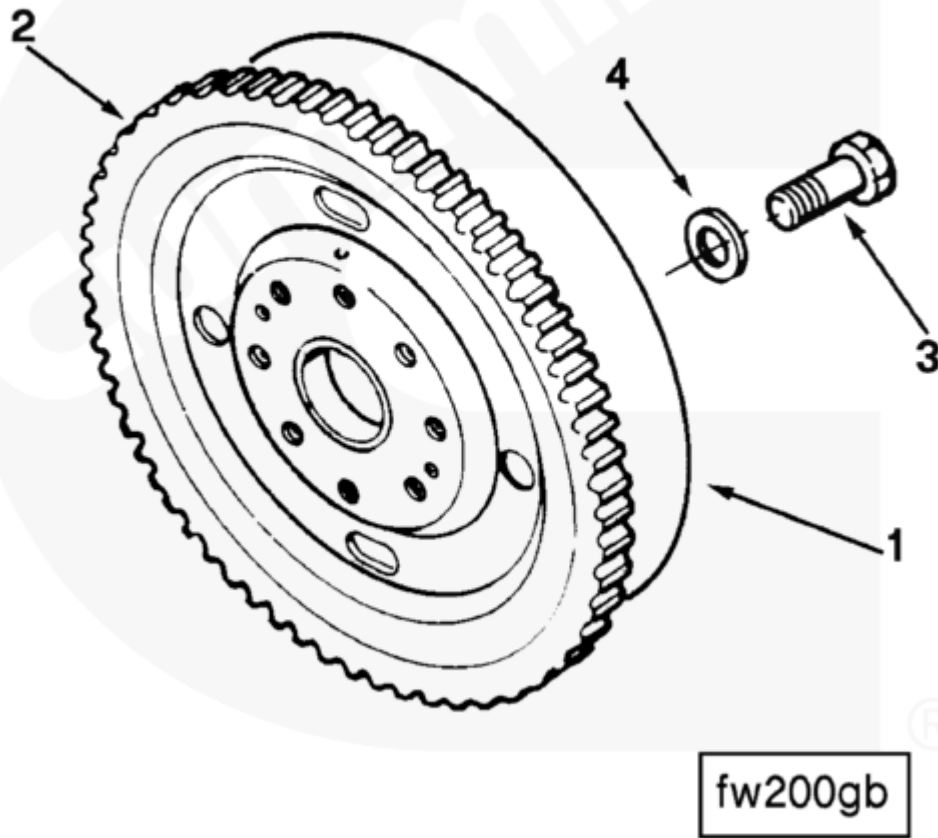

## Parts Catalog - Option Detail

Electronic Parts Catalog - Option Detail				
Option	Group	Graphic	Film Card	Date
FW2146-02	16.02	fw200gb	II	04-AUG-04
<b>Engines</b>	ISM CM570, ISM CM570/870, ISM CM875, ISM CM876, ISM CM876 E, ISM11 CM876 M103, ISM11 CM876 SN, M11 CELECT, M11 CELECT PLUS, M11 MECHANICAL, QSM11 CM570, QSM11 CM876			

©Cummins Inc



[SMALL](#) | [MEDIUM](#) | [LARGE](#)

Cart	Ref No	Part Number	Part Description	Required	Remarks
<a href="#">View My Cart</a>					
		<a href="#">FW2146-02</a>	Flywheel		
					Flywheel
					Type: Flywheel

					Intended Housing SAE: 1 Only
					Starter Center Distance:
					275.59mm (10.85 in.)
					Clutch Bearing Pilot Bore
					Dia: 52.00mm (2.05 in.)
					Clutch Size: 16 inch
					Rear Gear Drive: No
					Intended Drive Hardware:
					Clark C 5000, C 8000, &
					HR34000,
					Torque Converter
					Unique Characteristics: 52mm
					Pilot
					OEM must furnish (8) 7/16 x
					20 x1.5 inch (min) Flexplate
					mounting capscrews. The
					Capscrews must be socket head
					or 12 point heads in order to
					clear ring gear rim. For the
					same reason, no washers may
					be used either.
<input type="checkbox"/>		<a href="#">3899566</a>	Flywheel	1	
	1	<a href="#">3899565</a>	Flywheel	1	
<input type="checkbox"/>	2	<a href="#">4851</a>	Flywheel Ring Gear	1	
<input type="checkbox"/>	3	<a href="#">3328765</a>	Hexagon Head Cap Screw	8	
<input type="checkbox"/>	4	<a href="#">3899664</a>	Plain Washer	8	